

Instruction Manual
for
Valve Control

Type LTRH-01/LTRM-01



SEIBU ELECTRIC & MACHINERY CO., LTD.

Head office&Factory : Koga,Fukuoka,JAPAN 811-3193

Phone (092)941-1507 Fax (092)941-1517

CAUTION

(1) Prior to starting of wiring works for Valve Control, pay attention to the following items.

Instructions for Handling the Valve Control.

- 1 • 1 When closing the switch cover, clean the mating surfaces ensure the gasket is complete, and tighten the fitting bolts securely.

In the case of "Explosion-proof type", when the liquid gasket on the mating surfaces is stained by sand and dust, clean up with solvent and apply non-drying liquid gasket or non-drying oil.

Remember that careless untightening or insufficient tightening of bolts causes the spoiling of the explosion-proof function.

- 1 • 2 Cable entrance should be sealed to prevent the ingress of rain water.
- 1 • 3 Do not leave the switch cover or terminal cover open after wiring, adjusting or inspections.
- 1 • 4 When Valve Control is installed outdoors, wiring works in the rain should be strictly avoided.
- 1 • 5 Do not leave the Valve Control in dirt and sand or water puddles, except the water-proof type.
- 1 • 6 In the case of "Explosion-proof type", the rain protective cover should be provided for outdoor use.
- 1 • 7 Connect the power cables of U, V and W to the motor terminals of R, S and T respectively (R-U, S-V, T-W), and the valve will be opened.

(2) Refer to the following clauses of this operation manual before having a trial operation.

- 1. TRIAL OPERATION
- 2. POWER-MANUAL CHANGE-OVER
- 7. POWER OPERATION
- 8. MANUAL OPERATION

(3) When reinstalling a Valve Control which has been once removed from the valve, check and adjust each section of the device once more in accordance with this operation manual.

CONTENTS

1	TRIAL OPERATION	1
1 · 1	Preliminary Check	1
1 · 2	Preparation for Power Operation	1
1 · 3	Checking of the Valve Operating Direction	2
1 · 4	Checking of the Limit Switch Operation	2
1 · 5	Checking of the Torque Switch Operation	2
2	DESCRIPTION OF MECHANISM	3
2 · 1	General	3
2 · 2	Power Operation Mechanism	3
2 · 3	Manual Operation Mechanism	4
2 · 4	Power-Manual Change-Over Mechanism	4
2 · 4 · 1	Power-to-Manual Change-Over	4
2 · 4 · 2	Manual-to-Power Change-Over	4
	Attached Drawings : Construction (Fig. 2)	5
	Change-Over Mechanism (Fig. 3)	6
3	LIMIT SWITCH	7
3 · 1	Setting of Limit Switch	7
3 · 1 · 1	Setting Procedure	7
	Chart 1	8
	Chart 2	9
4	TORQUE SWITCH	10
4 · 1	Setting of Torque Switch	10
5	POSITION INDICATOR	11
5 · 1	Setting of Local Position Indicator	11
5 · 2	Setting of Remote Position Indicator	11
6	MOTOR	12
7	POWER OPERATION	12
8	MANUAL OPERATION	12
9	MAINTENANCE	13
9 · 1	Lubrication	13
9 · 2	Others	13
10	STANDARD TERMINAL ARRANGEMENT AND SEQUENCE DIAGRAM	14

Disassembling and Assembling the Stem Bushing

Take the following steps on disassembling and assembling the stem bushing from/into Valve Control.

Disassembling

1. Put the Valve Control with the switch cover upward.
2. Take off the retaining ring① out of the sleeve③ with a retaining ring pliers.
3. Draw out the stem bushing② .

Assembling

1. Lubricate the interior surface of the sleeve ③
 2. Insert the stem bushing② into the sleeve taking care of adjusting splines of both parts.
 3. Insert the retaining ring① into the sleeve.
- ※ Caution : Confirm that the retaining ring has been fit to the groove of the sleeve surely.

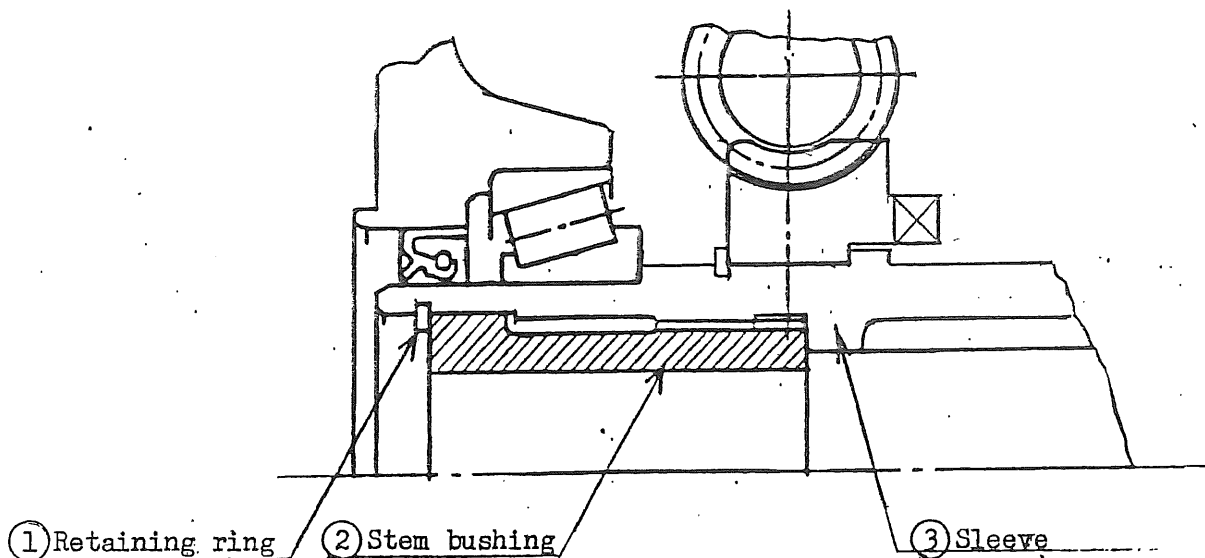

Fig. 1

1 TRIAL OPERATION

The trial operation should be performed in accordance with the following instructions.

1 • 1 Preliminary Check

- (1) Check electrical terminal connections referring to the terminal code label attached to the inside of the switch cover of the Valve Control.
- (2) Connecting the conduit tube or waterproof flexible conduit to the wiring entrance, and using the liquid packing agent or seal tape on the screw surface, certify that rain water can not enter it.
- (3) Make sure that the space heater for anti-condensation is not incontact with electrical wiring.
- (4) The space heater should be surely energized, especially this must be done when the Valve Control is kept in wet place before mounting.
- (5) Wash the exposed parts of the valve stem and stem bushing and apply lithium soap grease to them.
- (6) Make sure that there will be nothing to impede the movement of levers of the limit switch and that of the torque switch.
- (7) Make sure that the switch cover has been closed tightly again after once removed for making electrical wiring or adjustment.
Incomplete fastening of the cover may cause trouble from entry of rainwater.
- (8) Make sure that fuses at main power supply switch have not blown out.
- (9) Make sure that thermal overload relay has not operated.
- (10) When the Valve Control and valve are separately supplied, the trial operation must be performed in accordance with suggestions obtained from the manufacturer's representative at the work site.

1 • 2 Preparation for Power Operation

Manually, open the valve to the half way position before any adjustments are made in the power mode, so as not to damage the valve.

1 • 3 Checking of the Valve Operating Direction

- (1) Open the valve manually to the intermediate position.
- (2) Confirm that the indication on the handwheel coincides with the direction of valve movement.
- (3) Operate the push-button switches in the order of OPEN→STOP→CLOSE→STOP to check if the motor starts or stops surely.
- (4) When terminals U, V and W are connected respectively to the power source R, S and T the valve can be operated to open direction.

Therefore check that when the push-button "OPEN" is pressed, the valve opens and when the push button "CLOSE" is pressed, the valve closes. If these actions are found to be in reverse, change two lead wires among three in the switch compartment.

- (5) In conjunction with the above step, confirm that the pointer of the position indicator also moves in the correct direction.

1 • 4 Checking of the Limit Switch Operation

After checking the direction of the valve movement described above, confirm that limit switch operates at the predetermined position as follows :

- (1) First press the CLOSE push button, and stop the valve shortly before it reaches its fully closed position : then slowly close the valve further manually.
- (2) Check whether the arrow pointer of the limit switch on the closing side points to the mark A simultaneously with full closing.
- (3) Similarly check whether the arrow pointer of the limit switch on the opening side points to the mark A upon full opening.
- (4) When the above (2) and (3) conditions are not obtained, re-adjust the limit switch in accordance with the paragraph 3.1 [Setting of Limit Switch].
- (5) Notwithstanding the limit switch is properly set, if the motor stops shortly after starting the valve operation from the fully closed position, this is because of the operation of the opening torque switch.

Similarly if the motor stops shortly after starting the valve operation from the fully opened position, this is because of the operation of the closing torque switch.

In either case, re-adjust the torque switch in accordance with the paragraph 4.1 [Setting of Torque Switch].

1 • 5 Checking of the Torque Switch Operation

The torque switch is normally set at the valve manufacturer's plant.

If the indicating hand points to the red portion of the scale, that is out of the permissible operating range, readjust the torque switch in accordance with the paragraph 4.1 [Setting of Torque Switch].

2 DESCRIPTION OF MECHANISM (Refer to Fig. 2—page 5)

2 · 1 General

These types of Valve Controls are designed for motorized actuation of relatively small sized valves.

The major components of a Valve Control are an electric motor and a reduction gear system. A Valve Control is also provided with such auxiliary mechanisms as (1) a position indicator, (2) a limit switch to permit automatic stop control at the fully opened, fully closed or any predetermined position, (3) a double torque switch to prevent over-load damage to some valve parts from excessive torque, and (4) a handwheel for manual operation.

To change-over from power operation to manual operation, the change lever is used.

Type LTRM : Manual to power change over is achieved automatically by starting the motor. and power operation has the priority.

Type LTRH : Manual to power change over is achieved by lifting the change lever up, and manual operation has the priority as it has an interlocking switch to prevent the motor from starting while manual operation even if any start button were pressed .

2 · 2 Power Operation Mechanism

Type LTRM : The motor starts by pressing "CLOSE" or "OPEN" button,

Type LTRH : When "CLOSE" or "OPEN" push-button is pressed by having the change lever on the power operation side, the motor starts,

and the rotation speed of the motor is reduced by one-stage spur gear reducer consisting of the gear A ② and gear B ③ as shown in Fig. 2 and one-stage worm gear reducer consisting of the worm ⑦ and worm wheel ⑧, and then it is transmitted to the sleeve ⑨ through the clutch ⑥ to open and close the valve which is connected to the stem bushing ⑩ inserted inside the sleeve.

The worm is connected to the gear boss with sliding key and transmits rotating force, and is designed to be movable in the axial direction.

In normal condition, this worm is held in normal position by the torque spring ⑬.

However, if the valve comes to require abnormally large operating force, worm is shifted in axial direction compressing the torque spring.

This motion is used to operate the torque switch.

The limit switch ⑭ is operated by the rotation transmitted from the sleeve through the crown

gear ⑤④ and functions automatically to stop the opening or closing operation of the valve at the fully opened, fully closed or any predetermined position.

If the "STOP" push-button is pressed, the valve stops immediately regardless of valve position.

Although the worm wheel can move freely on the sleeve, it engages with the clutch ⑤③, in case of power operation, and rotates as one body with the sleeve.

Furthermore being connected to the sleeve spline, this clutch is movable in axial direction.

Besides, there is a play of about 90° between the clutch pawls : and by hammer blow effect utilizing the force of inertia of motor rotor, the opening and closing of the valve are made easily.

2 · 3 Manual Operation Mechanism

To operate the valve manually, press down the change lever ⑤⑤ in Fig. 2 to manual operation side : then as the upper side pawls of the clutch ⑤③ engages with pawls of the handwheel, the valve can be opened or closed by rotating the handwheel to which the sleeve is coupled directly.

2 · 4 Power-Manual Change-Over Mechanism

2 · 4 · 1 Power-to-Manual Change-Over

The clutch ⑤③, having pawls on both sides, can engage with either the worm wheel ③② or the handwheel ①⑦.

When the change lever ⑤⑤ in Fig. 2 is pressed down to manual operation side, the clutch moves to the handwheel side being pressed by the fork ④⑧ and disengages the pawls from the side of the worm wheel, and the pawls at the reverse side will come to engage with the pawls of handwheel, and the holding mechanism keeps the clutch in this position.

Note : It is recommended to shift the change lever while turning the handwheel to either direction for getting smooth change over.

Type LTRH : The interlock switch ④② opens the motor control circuit at the manual position to prevent power operation.

2 · 4 · 2 Manual-to-Power Change-Over

Type LTRM : Change over is performed automatically.

The wormwheel is driven by energizing the motor, then the cam holding the fork at manual position is tumbled, the clutch ⑤③ being pressed by the clutch spring ⑤② engages with the wormwheel, simultaneously, the change lever is lifted up automatically to power position.

Caution : Don't lift the change lever up forcibly as it is impossible to achieve by manual lever operation.

Type LTRH: If the change lever ⑤⑤, shown in Fig. 2 is lifted up to the power operation side, the clutch ⑤③ engages with the worm wheel ③② declutching the handwheel, and the interlock switch ④② makes the contact. This condition is kept by the clutch spring ⑤②.

FIG. 2 CONSTRUCTION

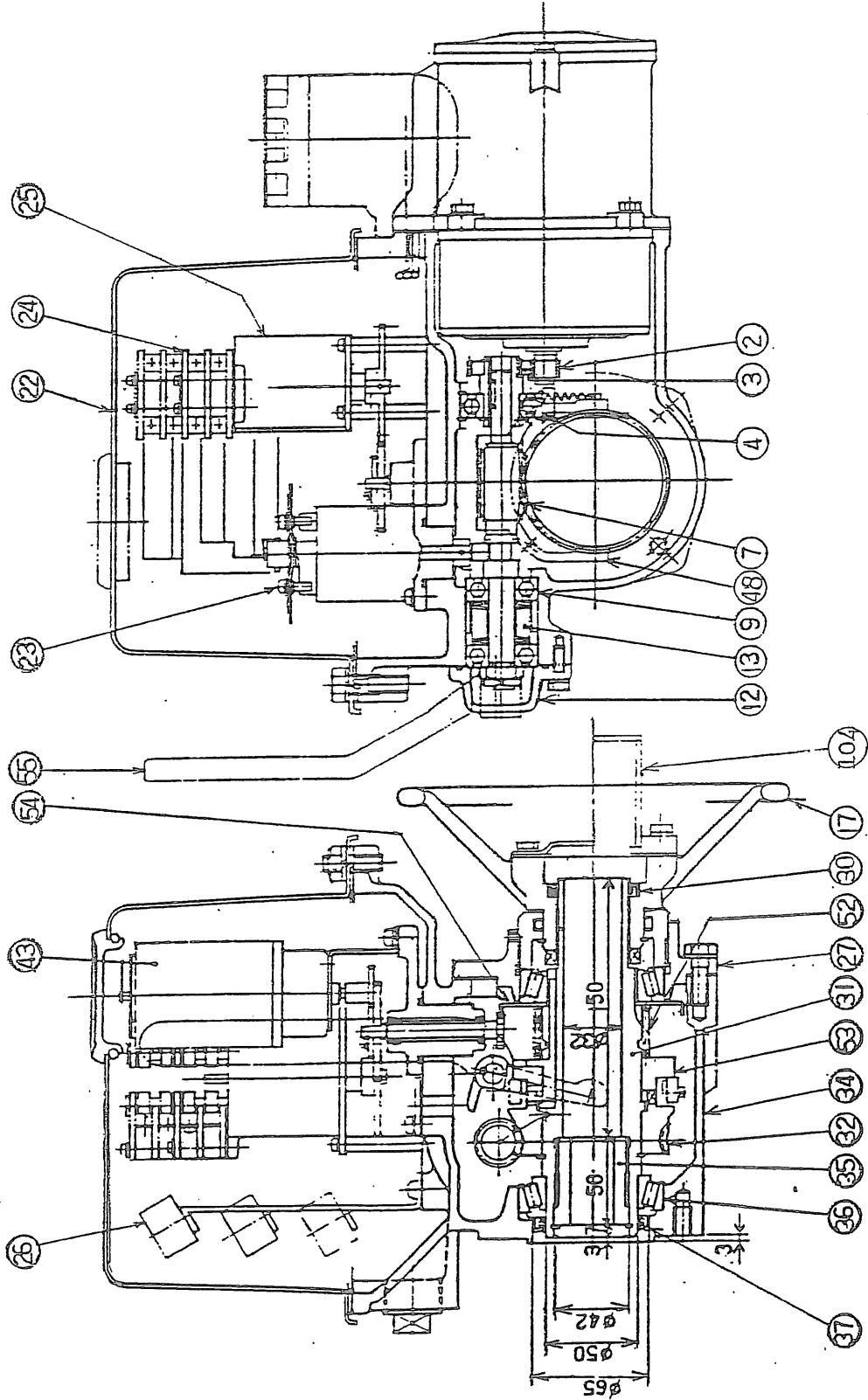

No	Parts name
2	Gear A
3	Gear B
4	Bearing
7	Worm
99	Bearing
12	Spring cover
13	Torque spring
17	Handwheel
22	Switch cover
23	Torque switch
24	Limit switch
25	Counter Mechanism
26	Terminal block
27	Cover
30	Oil seal
31	Sleeve
32	Worm wheel
34	Gear case
35	Stem bushing
36	Bearing
37	Oil seal
42	Interlock switch
43	Position indicator
48	Fork
52	Clutch spring
53	Clutch
54	Crown gear
55	Change lever
104	Spindle cover

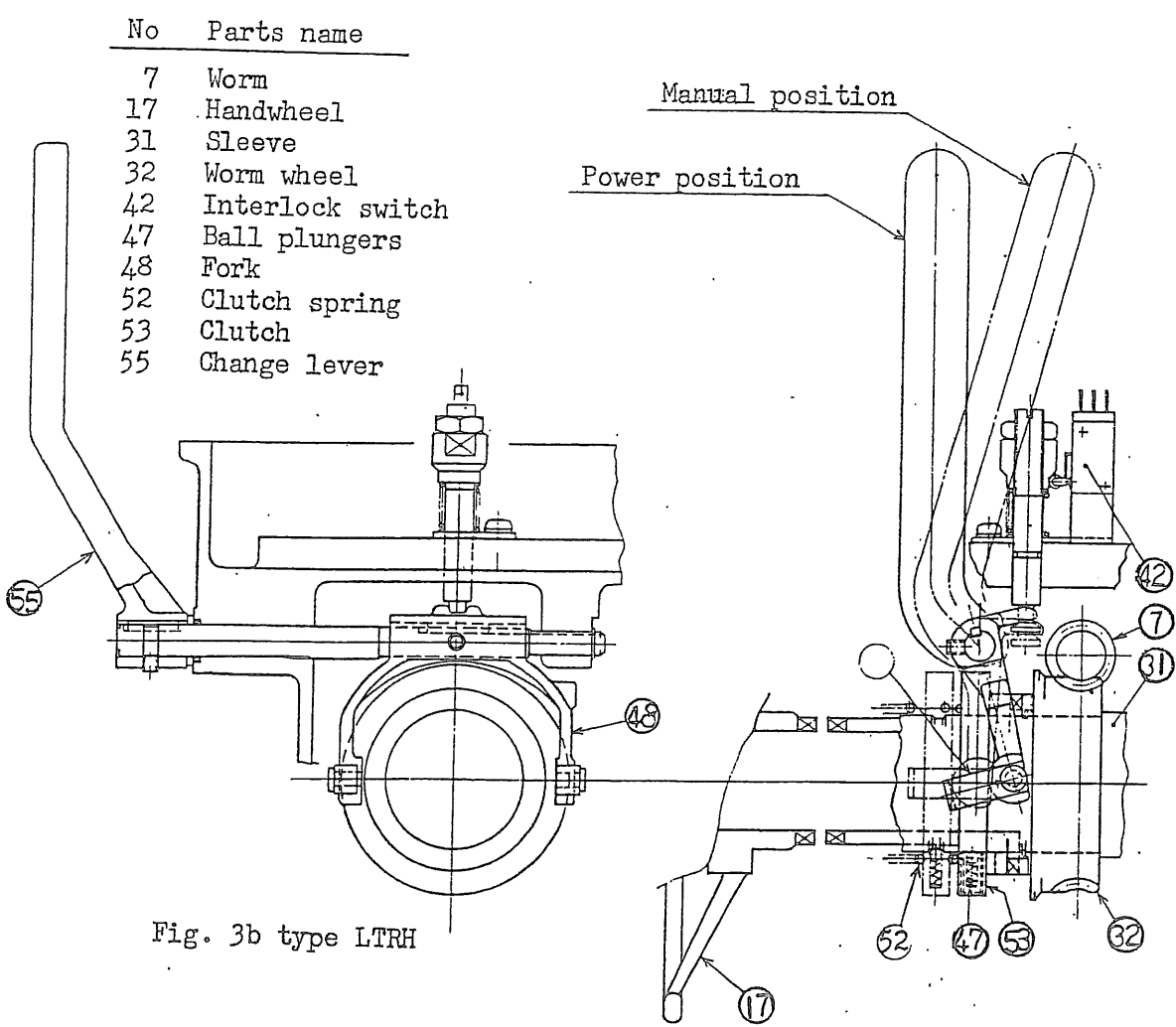
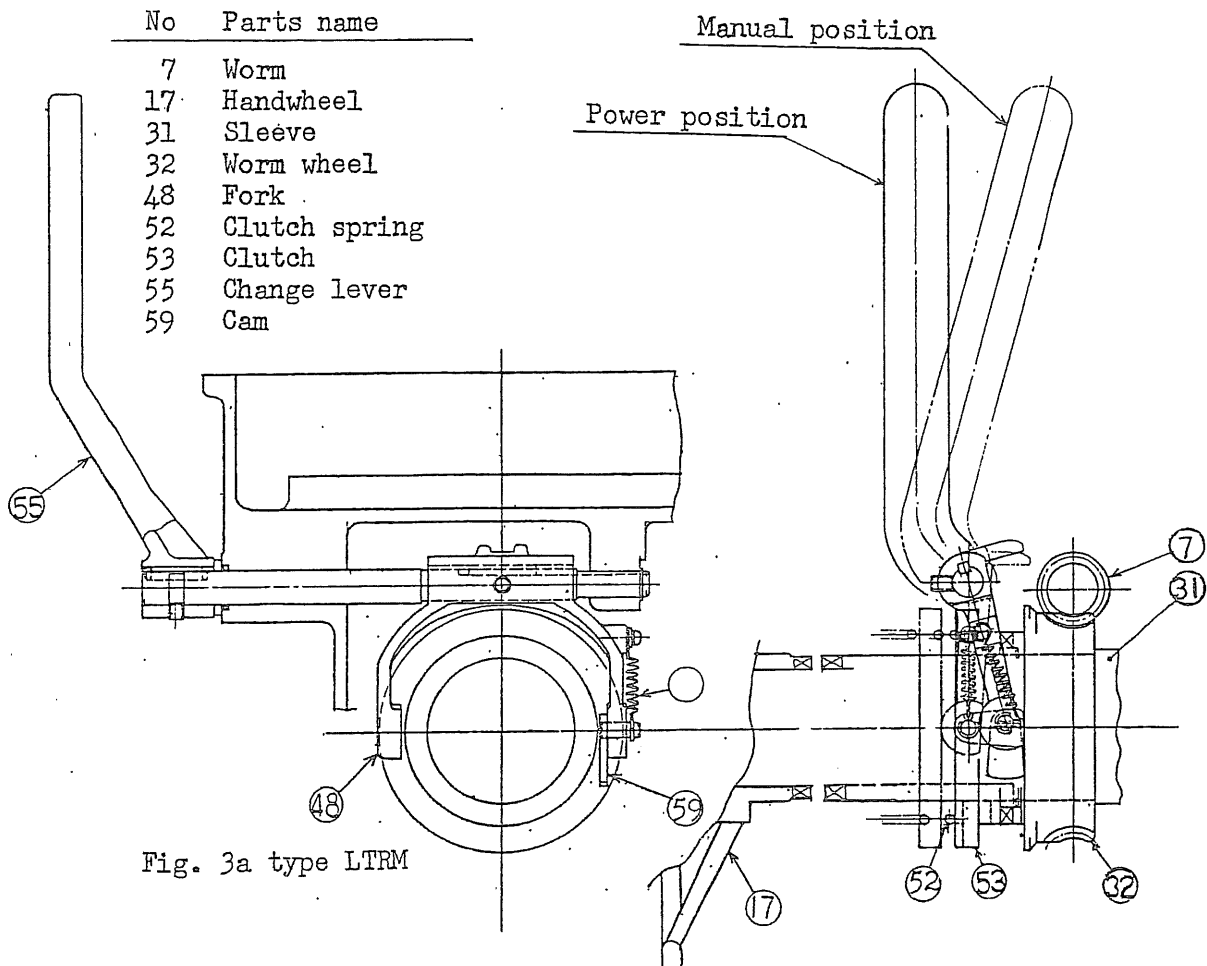

3 LIMIT SWITCH

As the standard, limit switch is provided with cam switches.

The setting of limit switch is completed at the valve manufacturer's plant.

If field setting is required, take the following procedure.

3 - 1 Setting of Limit Switch

Set the limit switch for the close side first, and later for the open side.

3 - 1 - 1 Setting procedure

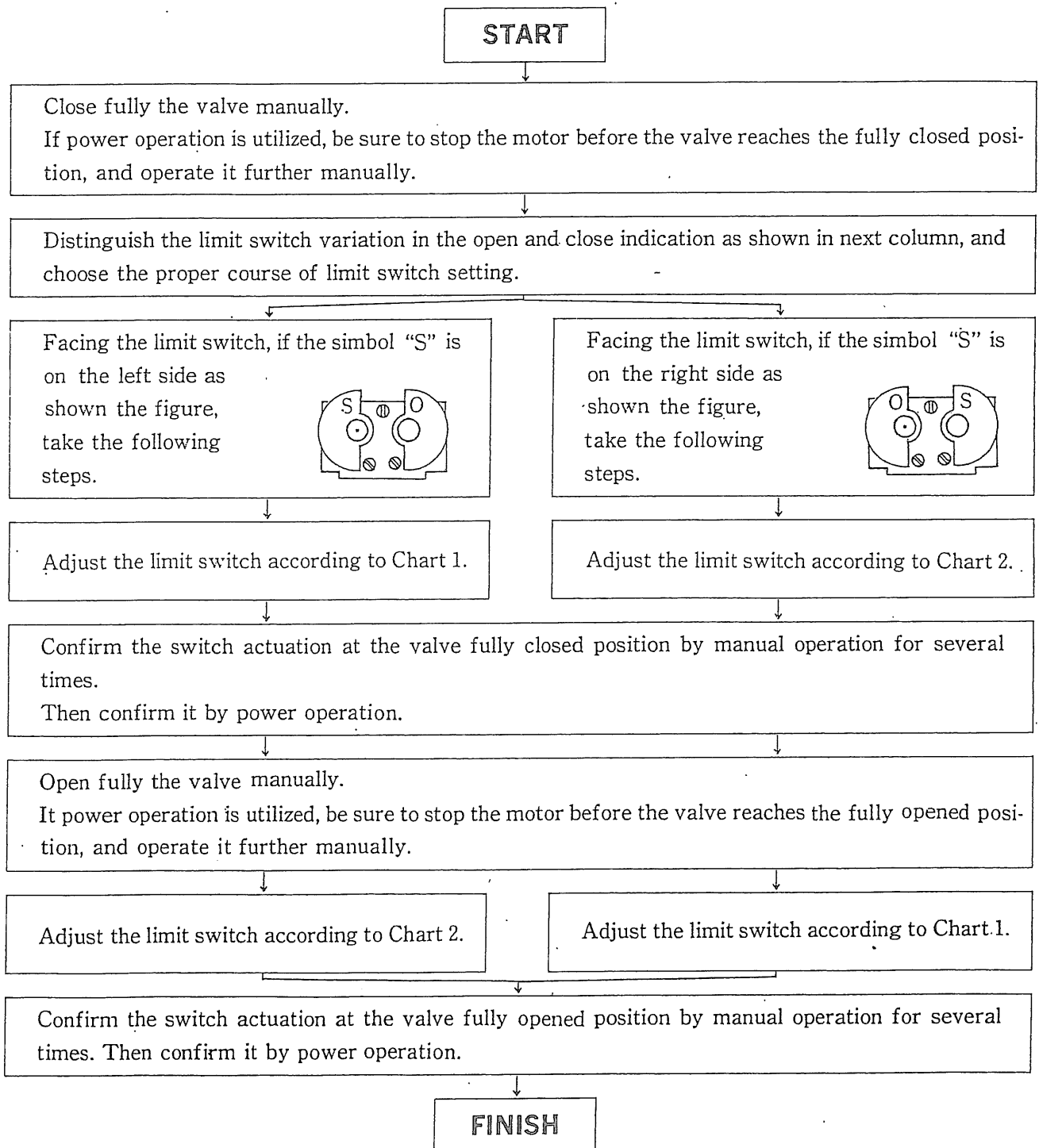
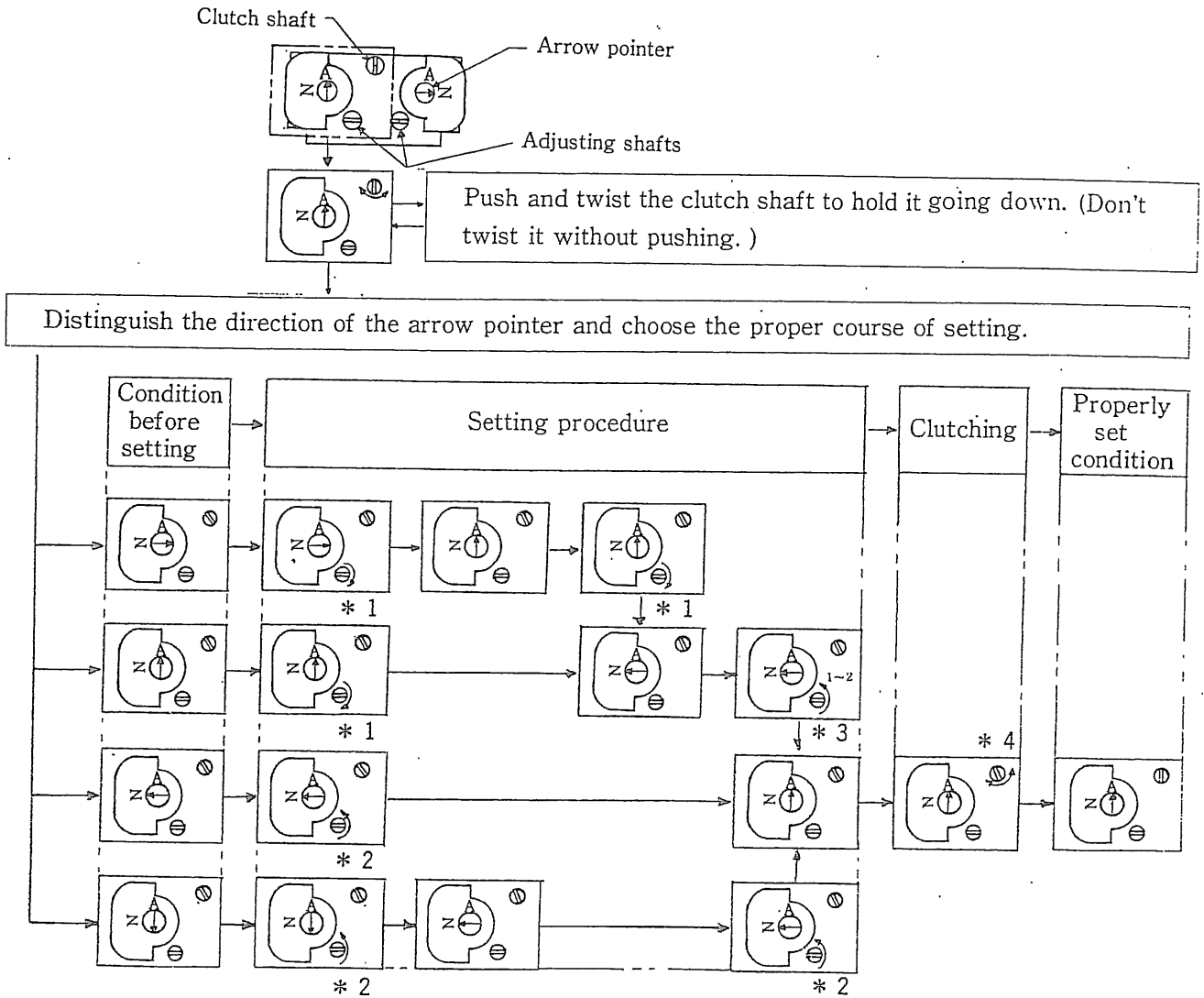

Chart 1



Explanation of figures

- * 1 : Turn the adjusting shaft clockwise until arrow pointer change the direction.
- * 2 : Turn the adjusting shaft counterclockwise until arrow pointer changes the direction.
- * 3 : Turn the adjusting shaft counterclockwise once or twice until arrow pointer changes the direction.
- * 4 : Twist the clutch shaft to come up. (If the valve is operated without coming up of the clutch shaft to the original position, the adjustment will come to nothing.)

Phot. 1

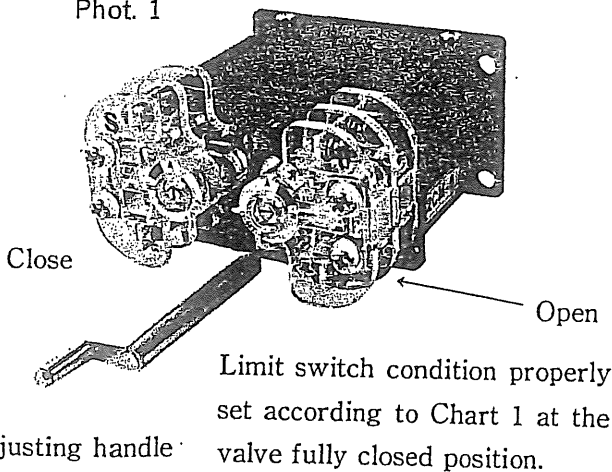

Phot. 2

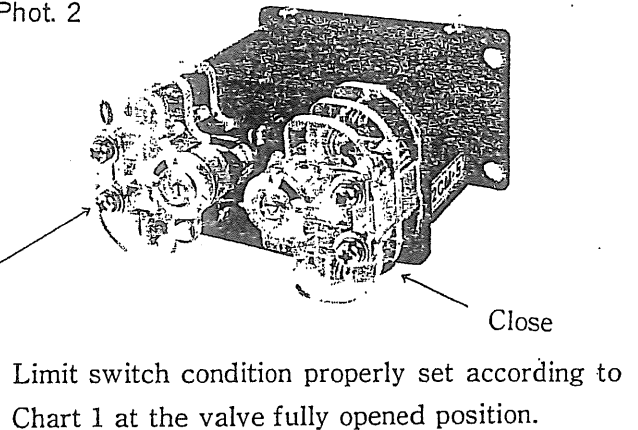
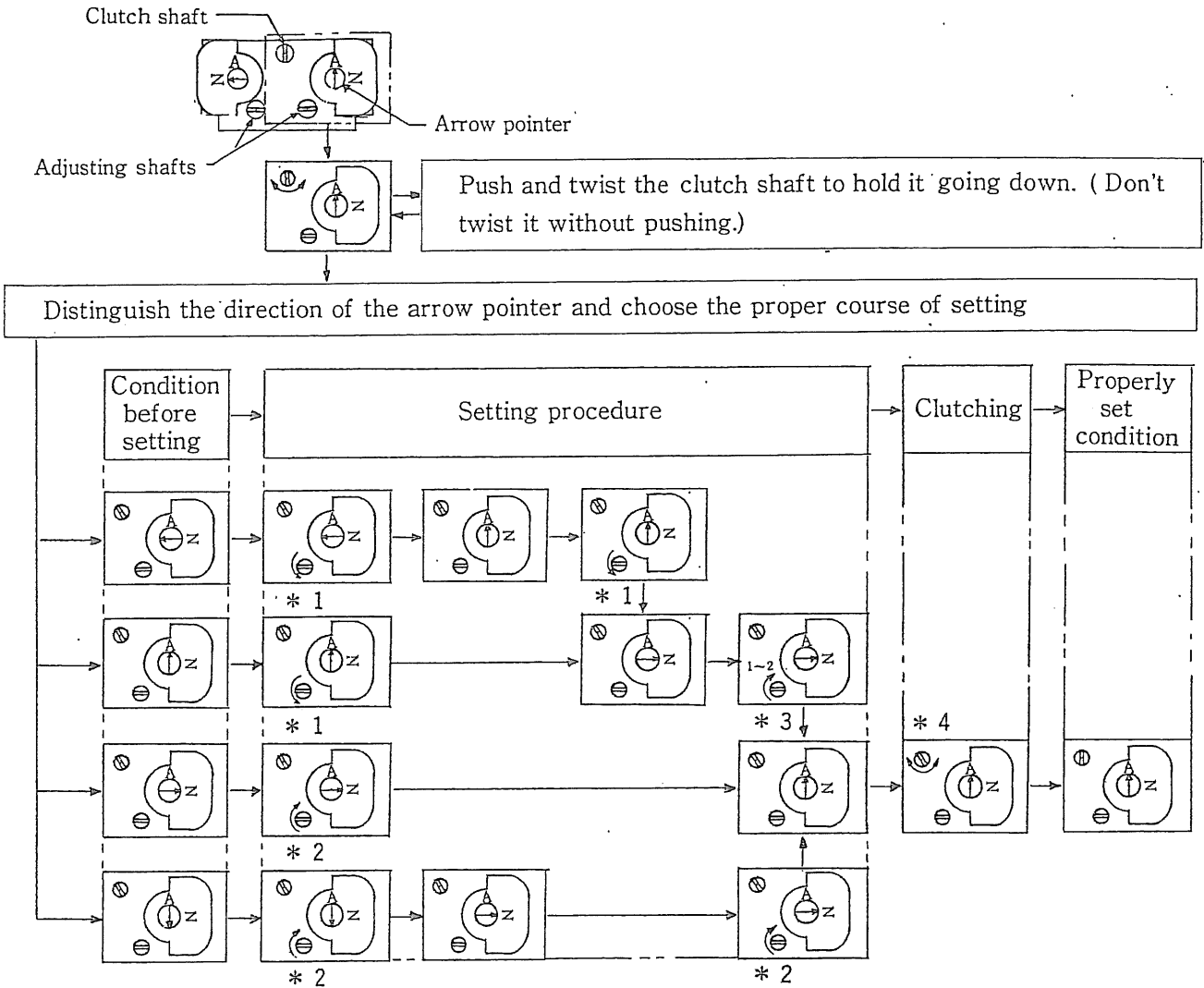

Chart 2



Explanation of figures

- * 1 : Turn the adjusting shaft counterclockwise until arrow pointer changes the direction.
- * 2 : Turn the adjusting shaft clockwise until arrow pointer changes the direction.
- * 3 : Turn the adjusting shaft clockwise once or twice until arrow pointer changes the direction.
- * 4 : Twist the clutch shaft to come up. (If the valve is operated without coming up of the clutch shaft to the original position, the adjustment will come to nothing.)

Phot. 3

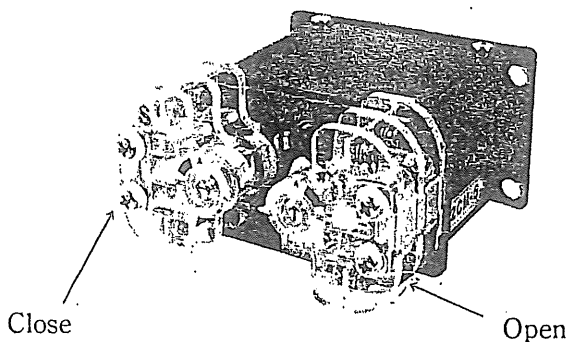

Limit switch condition properly set according to Chart 2 at the valve fully opened position.

Phot. 4

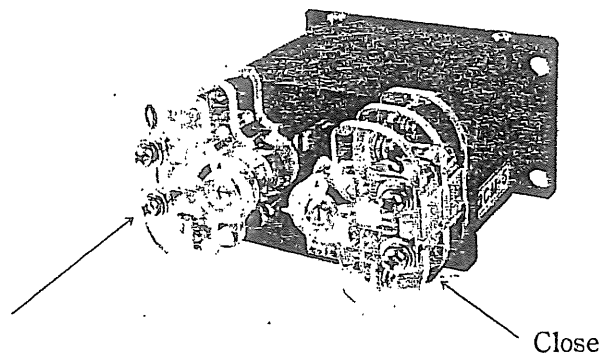

Limit switch condition properly set according to Chart 2 at the valve fully closed position.

4 TORQUE SWITCH

As described in the paragraph 2.1, the torque switch functions automatically to stop the motor when an excessive torque is applied to the valve stem.

The torque switch is provided with two switches for both opening and closing the valve, and they can be adjusted independently.

4 - 1 Setting of Torque Switch

The torque switch is adjusted at factory before shipment so that it will operate at proper torque. If readjustment of the torque switch is required by some reason, take the following steps.

The operating torque will increase in proportion to the scale indication on the switch dial. When the adjusting screw (refer to Fig. 4) is loosened, the pointer can be freely moved.

First, set the pointer to position 1 on the scale and operate the valve electrically. Now, as the torque switch operates prior to the operation of the limit switch, gradually move the pointer toward larger indication on the scale.

An ideal setting is such that the torque switch will operate immediately after tripping of the limit switch.

Operation of the limit switch can be identified by watching the signal lamp or by the movement of the arrow pointer of the limit switch

Adjust the torque switch for opening direction and closing direction separately.

After completion of the setting, fully tighten the adjusting screw.

Note : Don't touch the zero point adjusting screw as it is already adjusted.

Fig. 4 CONSTRUCTION OF TORQUE SWITCH Phot. 5 TORQUE SWITCH

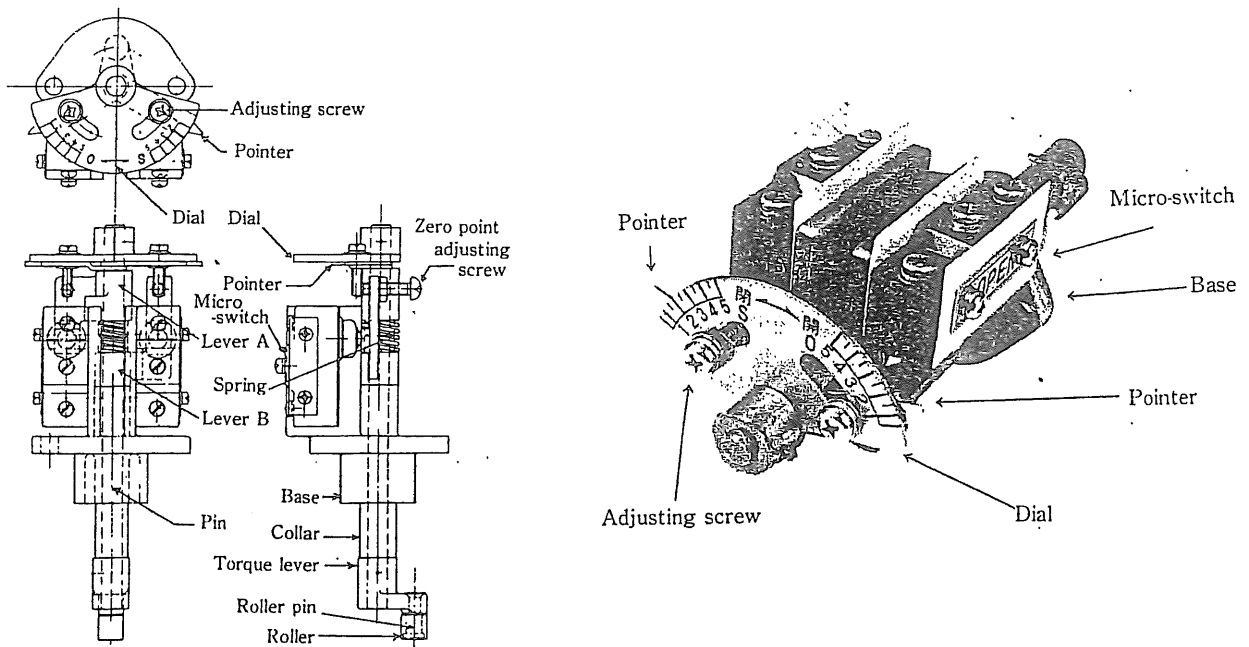

5 POSITION INDICATOR

The local position indicator is provided in the Valve Control.

In the case of remote indication, a transmitter is mounted inside of the local position indicator and a receiver is mounted on the remote control panel.

5 · 1 Setting of Local Position Indicator (Refer to Fig. 5)

Fully close the valve, remove the switch cover and pull the pointer out.

Set the pointer to zero position and press in.

5 · 2 Setting of Remote Position Indicator

- (1) In case of synchro motor (selsyn), the adjustment of synchro transmitter is not necessary. Setting of synchro receiver is achieved by adjusting the pointer of receiver to that of transmitter applying the rated voltage. If the pointer of the receiver turn reversely to the transmitter, change the connections of two lead wires among three which are connected to terminals S1, S2 and S3.

As the pointer is of the press in type, pull it out by holding its base part, in case of removing.

- (2) Potentiometer (Refer to Fig. 6)

Adjustment of transmitter should be performed simultaneously with the setting of pointer of the local position indicator.

Close the valve fully, loosen a set screw of the joint for the potentiometer, and find the zero ohm point between terminals A and B using a circuit tester while turning the potentiometer by the pointer. When the resistance just reaches zero ohm, tighten the set screw of the joint, and finally set the pointer to fully closed position. Adjustment of remote indicator is achieved by opening the valve fully and adjusting the span of R/I converter (SEIMITTER), and then adjust the zero point, closing the valve fully. Make minute adjustment by repeating this procedure two or three times.

Fig. 5 POSITION INDICATOR WITH SYNCHRO TRANSMITTER Fig. 6 POSITION INDICATOR WITH POTENTIOMETER

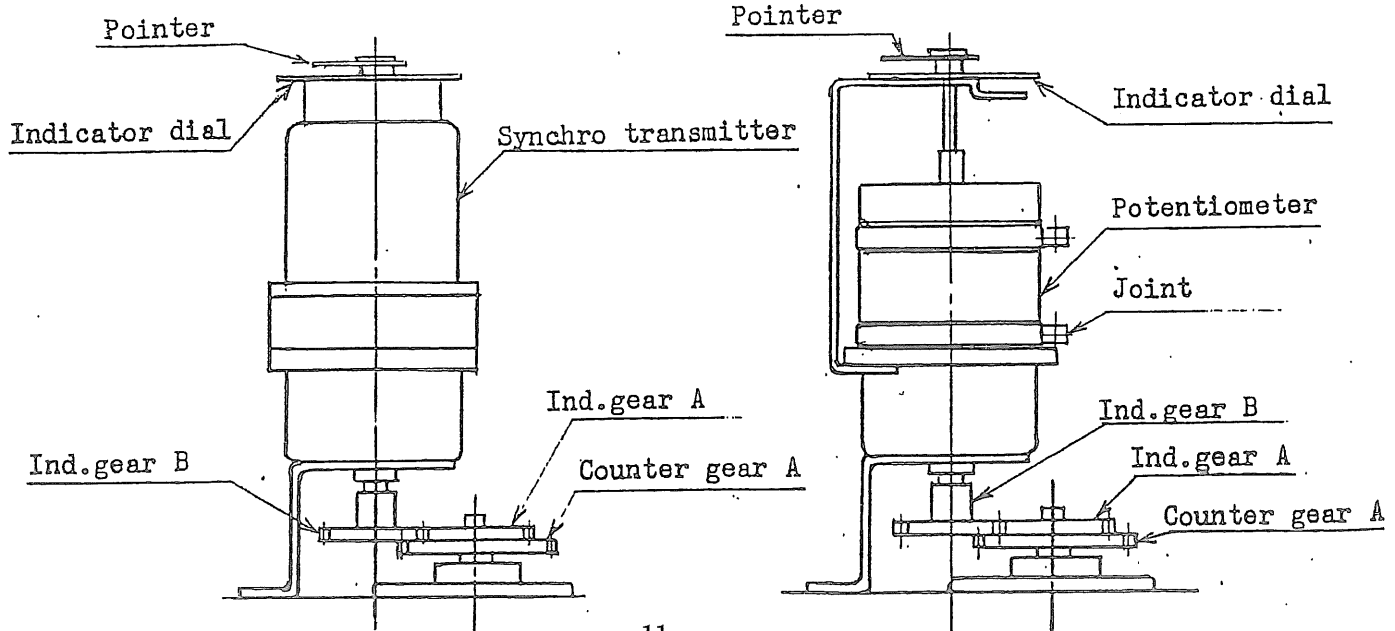

6 MOTOR

As a standard, a specially designed high resistance squirrel-cage type 3-phase induction motor of special-flange mounted, class E insulation and totally enclosed non-ventilated for outdoor-use (IPW-55) is applied.

This motor features 250% or higher starting torque, low starting current, and very small moment of inertia of the rotor.

A brake motor or a DC motor is also available upon request.

7 POWER OPERATION

The Valve Control is normally operated by pressing the OPEN, CLOSE and STOP push-buttons. When the OPEN or CLOSE push-button for electrical operation is pressed, the motor starts to actuate the valve in the intended direction and the valve stops immediately upon pressing of the STOP push-button. At the fully opened or fully closed position, the limit switch actuates and stops the motor instantly. In the case of an automatic control or sequential control, the motor can be operated automatically by other electrical control signals.

8 MANUAL OPERATION

Press down the change lever ⑤ toward the manual operation side. The change lever will be kept by the holding mechanism at this position.

If change-over can not be made smoothly, shift the change lever while turning the handwheel ⑰ to the right or left.

When the change-over has been finished, the valve can be operated by manual.

Note : . In case of the manual operation, do not insert a bar into the handwheel to turn it.

Such way causes damage.

If abnormally large force is required, check for the causes before proceeding of operation.

9 MAINTENANCE

9 . 1 Lubrication

This Valve Control is lubricated with ample amount of Lithium soap grease of very longer life.

During normal operation of several years, renewal of grease is not necessary, but when the Valve Control is disassembled at the occasion of periodic inspection or for repair, renew grease in accordance with the following table.

Lithium soap grease of different brand can be mixed with each other : however avoid mixing with different soap base grease each other.

Type	Quantity of grease kg	Recommended Grease	
		Brand	Manufacturer
LTRM - 01 LTRH - 01	1	Hanyo grease No.0 Nigtight LYW No.0 Shell ALVANIA EP R0 Esso LITHTAN EP 0	KYODO YUSHI COMPANY NIPPON GREASE COMPANY SHELL OIL COMPANY ESSO STANDARD SEKIYU

9 . 2 Others

- (1) For the threaded part of the rising stem type valve, grease mixed the molybdenum disulphide should be applied regularly to diminish the wear of stem bushing.
- (2) In case the valve is seldom operated; it is recommended to establish a schedule of periodical (for example, once a week) test run for the valve, to confirm satisfactory operating condition.
- (3) Four fixing bolts of switch cover shall be tightened symmetrically by 50 -- 100 kgcm torque after checking the satisfaction of the gasket and removing dust or mud on the both surfaces.

10 STANDARD TERMINAL ARRANGEMENT AND SEQUENCE DIAGRAM

10 - 1 Standard Terminal Arrangement

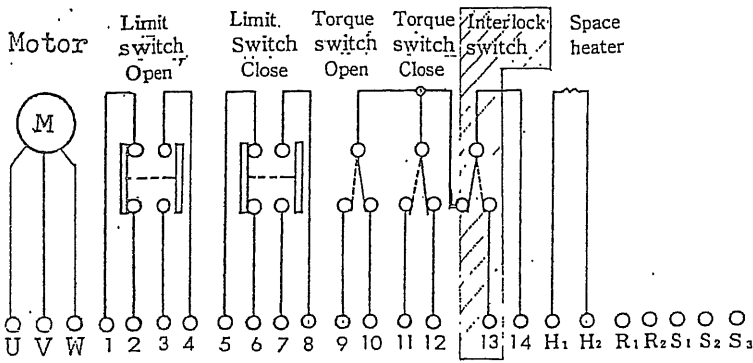

- 1~2 ...OFF at full opening
- 4~3 ...ON at full opening
- 5~6 ...OFF at full closing
- 8~7 ...ON at full closing
- 9~14 ...ON at opening over torque
- 10~14 ...OFF at opening over torque or by manual
- 11~14 ...ON at closing over torque
- 12~14 ...OFF at closing over torque or by manual
- 13~14 ...ON by manual
- H₁, H₂ ...Heater terminals
- R₁, R₂, S₁, S₂, S₃ ...Terminals for Synchro

Regarding the wiring on the terminal blocks, refer to the sequence diagram.

10 - 2 Terminal Arrangement in the Control Box

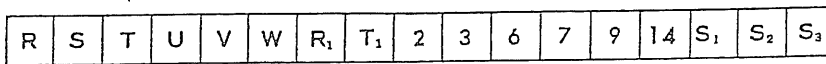

10 - 3 Sequence Diagram of Standard

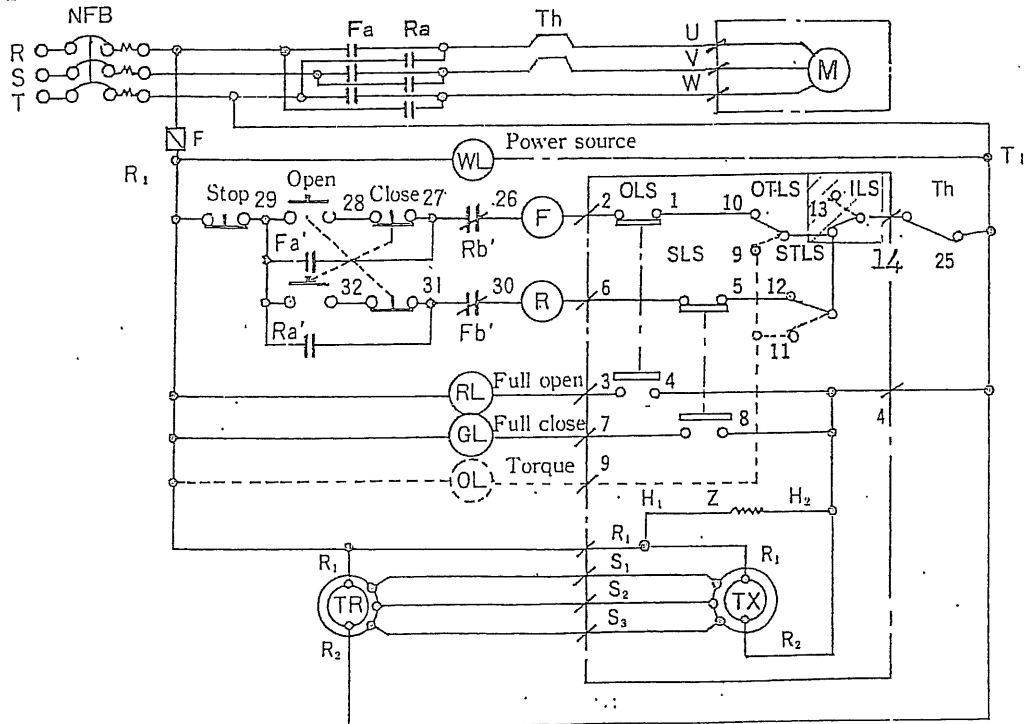

- Internal wiring of switch box and Motor terminal box.
- This wiring shows the case of over torque indication.
- Interlock switch is provided for type LTRH only.

NFB	No-Fuse Breaker	(GL)	Full close signal lamp (green)
Th	Thermal relay	(OL)	Torque signal lamp (orange)
(F)	magnetic switch open coil	OLS	Open limit switch (la, lb)
Fa	magnetic switch open main contact	SLS	Close limit switch (la, lb)
Fa' Fb'	magnetic switch open auxiliary contact	OTLS	Open torque switch (lc)
(R)	magnetic switch close coil	STLS	Close torque switch (lc)
Ra	magnetic switch close main contact	ILS	Interlock switch (lc)
Ra' Rb'	magnetic switch close auxiliary contact	Z	Space heater
Open, Close, Stop	3 push button switches	F	Fuse
(WL)	Power source signal lamp (white)	TX	Synchro transmitter
(RL)	Full open signal lamp (red)	TR	Synchro receiver

Seibu

SEIBU Electric & Machinery Co., Ltd.

Head Office & Factory:	Kubo, Koga-machi, Kasuya-gun, Fukuoka Prefecture. <i>Japan</i> 811-31 Telephone (092)943-7071 Facsimile (092)943-5148 Telex 729392 SEIBUF J
Tokyo Branch Office	Telephone: (03)271-3321. Facsimile: (03)273-1860
Osaka Branch Office	Telephone: (06)372-8271. Facsimile: (06)372-1785
Other Branch Office	Nagoya, Hiroshima, Sapporo, Sendai